

V292

Two-way Pressure Balanced Plug Valve, Flanged PN 25



The V292 valve is primarily intended to be used in heating, air conditioning and district heating installations with large pressure drops.

The V292 valve can be used with the following types of fluids:

- Hot water, or deaerated cooling water.
- Water with additives such as phosphate or hydrazine.
- Deaerated water with glycol-type antifreeze agent (max.50%)
- With cooling medias at temperatures below 0°C a stem heater must be fitted, to protect from stem seizure due to freezing.

Specifications

Design	Two-way pressure balanced plug valve		
Pressure class	PN 25		
Connection	Flange according ISO 7005-2		
Flow characteristics	EQ%		
ΔP_m	See sizing table, page 2		
ΔP_c	See sizing table, page 2		
Stroke			
DN 65...100	30 mm		
DN 125...150	50 mm		
Rangeability $K_v/K_{v_{min}}$ (IEC 60534-1)	>50		
Leakage	<0.05% of K_v s		
Stem			
DN 65...100	M8		
DN 125...150	M16		
	(fitted with Hex Bush for M22/M50 actuators)		
ΔP_m	1600 kPa, water		
Medium Temperature			
Max. temperature of medium	150 °C		
Min. temperature of medium	-10 °C		
Main Construction Materials			
Body	Nodular iron GGG40.3		
Stem	stainless steel SS 1.4021		
Plug	stainless steel SS 1.4021		
Seat	stainless steel SS 1.4021		
Packing box	Spring-loaded PTFE-V-ring		

Available Part Numbers

Size DN	K_v m ³ /h	Part number	Pressure Equipment Directive PED 2014/68/EU	CE marked
65	63	7219254010	Module H	CE
80	85	7219258010		
100	130	7219262010		
125	250	7219266000		
150	350	7219270000		

Key to Technical specification

- The rangeability is the ratio of K_v and $K_{v_{min}}$.
- K_v s is the flow through the valve in m³/h at the specified valve lift and at a pressure drop of 100 kPa across the valve.
- $K_{v_{min}}$ is the minimum controllable flow at a pressure drop of 100 kPa, within the flow range where the characteristic meets the requirements on characteristic slope according to IEC 60534-1.
- ΔP_m is max. pressure drop across a fully open valve.
 ΔP_c is max. close-off pressure drop across the valve.

Accessories and Spare Parts

	DN 65-100	DN 125-150
Gland Service Kit	100108201	100108210
Stem Heater	8800112000	8800113000
Hex Bush: Valve to actuator stem coupling	-	8800134000

Function and Flow Characteristic

The design of the V292 plug is pressure balanced to ensure high close off pressure with lower actuator force.

The valve closes with the stem down.

The flow characteristic of the V292 is equal percentage (EQ%, also called logarithmic), giving an equal-percentage change in flow.

The latter is necessary to give good control in systems with large load variations.

Valve and Actuator Sizing Table

Size (DN)	Kvs (m³/h)	ΔPm (kPa)	Max Close Pressure ΔPc (kPa)					
			M800	M1500 / MV15B	M3000	M700	M22	M50*
65	63	800	1500	2500	2500	1200		
80	85	400	1500					
100	130	150	1100	1600		800		
125	250	100	-				1800	2500
150	350						1400	

100 kPa = 1 bar

P_c = Maximum allowed pressure differential across a closed valve (a function of actuator performance)

P_m = Maximum allowed pressure across a fully 'open' valve (a function of hydronic valve performance)

*M22 and M50 actuators will not fit to valves DN65...100

Installation

The valve should be mounted with flow direction in accordance with the valve marking.

It is recommended to install the valve in the return pipe, in order to avoid exposing the actuator to high temperatures.

The valve must not be installed with the actuator mounted below the valve.

To ensure that suspended solids will not become jammed between the valve plug and seat, a filter should be installed upstream of the valve, and the pipe system should be flushed before the valve is installed.

EQ % in principle.

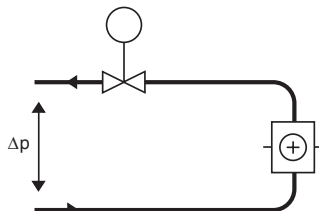
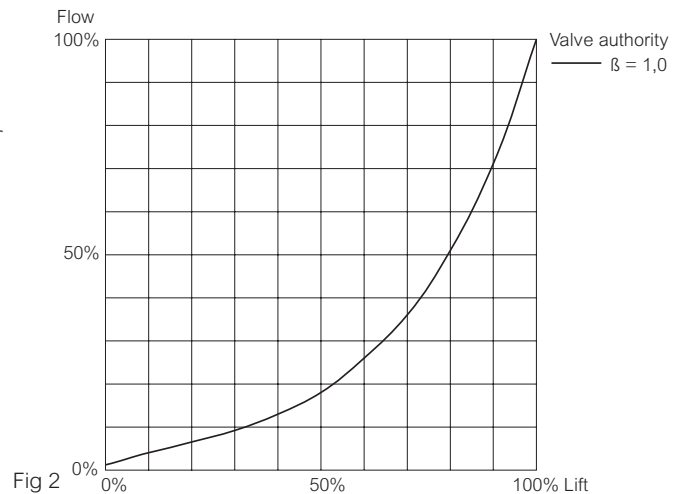

Fig 3

A. Typical installation without local circulating pump. To obtain good function the pressure drop across the valve should be no less than half of the available pressure drop (ΔP). This will give a valve authority of 50%.

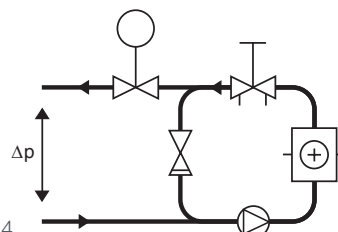

Fig 4

B. Typical installation with local circulating pump. The Kv value of the valve is to be selected so that the entire available pressure drop, ΔP, falls across the control valve.

Flow Capacity / Pressure Drop Charts, Fully Open Valve

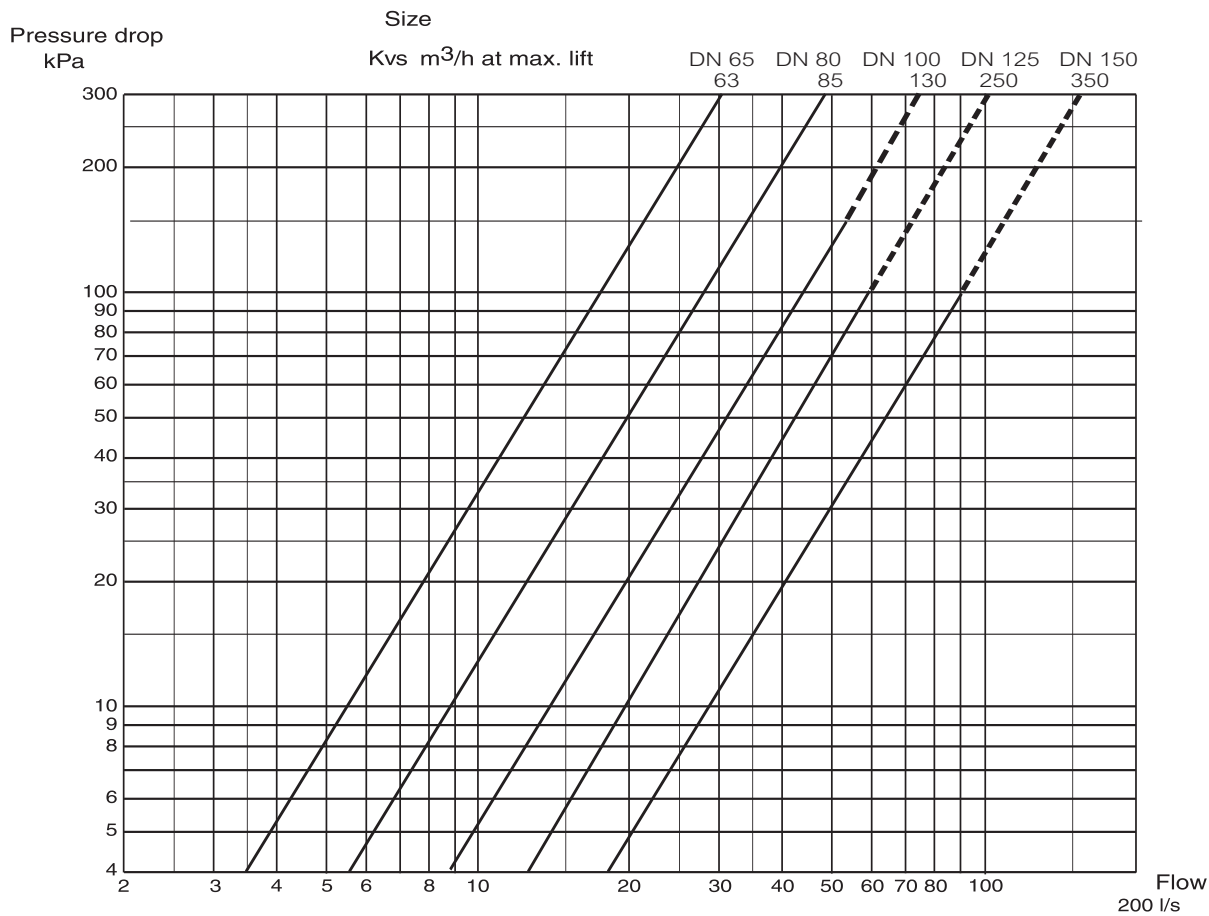

Fig 5

Cavitation

Cavitation takes place in a valve when the velocity of the fluid media over the plug and seat increases to such an extent that gas bubbles are created. As the fluid passes over the seat and the velocity decreases, these gas bubbles collapse (implode), generating considerable noise and erosion to the valve trim.

The cavitation chart provides guidance as to the cavitation zone where this phenomena will exist.

Chart usage:

- Using the y-axis, static pressure before the valve (e.g. 1000 kPa), plot the horizontal line to the line for the temperature of the liquid (e.g. 120 °C).
- From the intersection point, plot a vertical line downwards and read off the max. permissible pressure drop across the valve.
- If the computed pressure drop exceeds the value from the diagram, there is risk for cavitation.
- As a rule of thumb, to ensure the cavitation zone is not reached, the fluid velocity must be below 2 m/s.

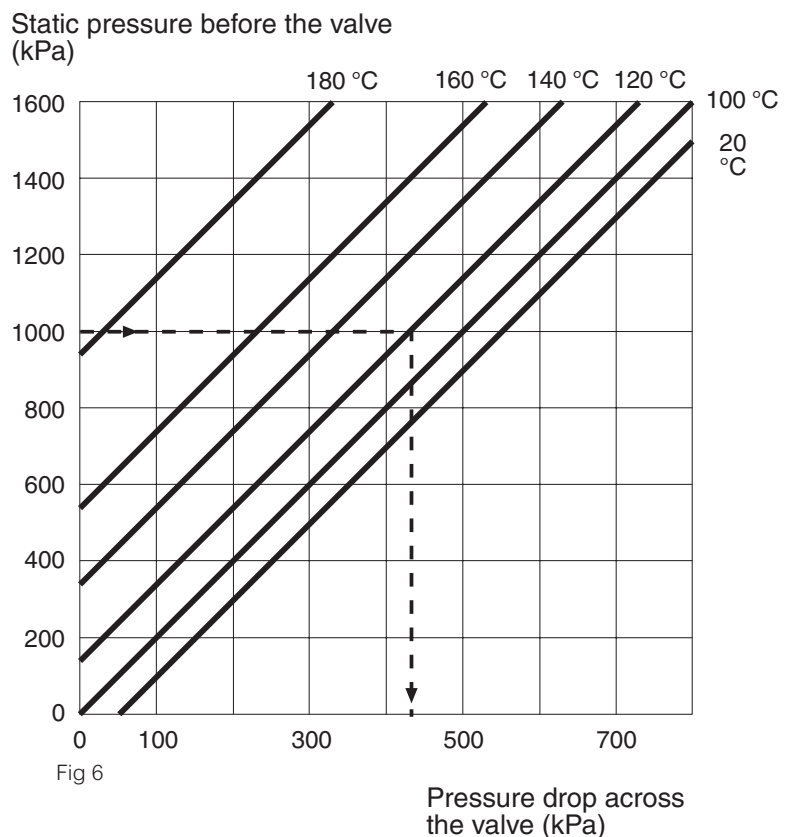

Fig 6

Dimensions and Weight

DN65, 80, 100

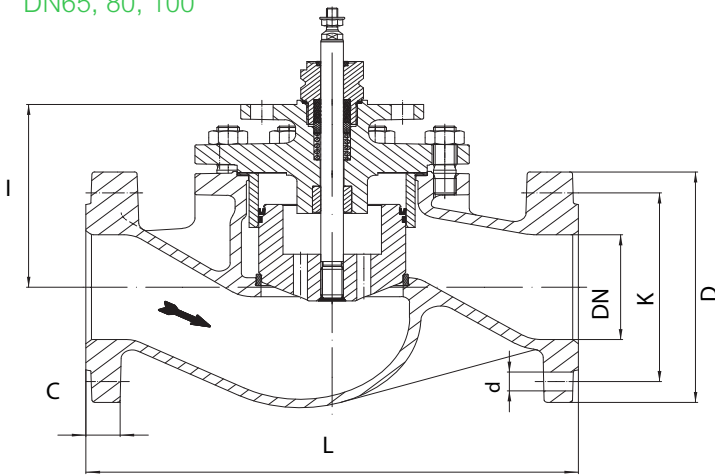
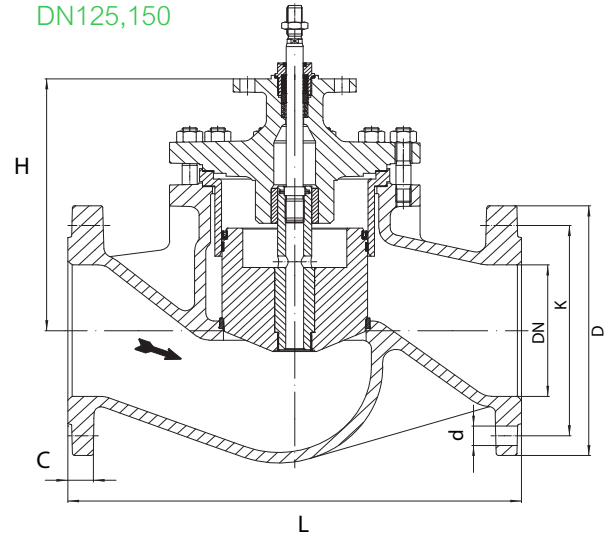

Fig 7

DN125,150



Part No	Size (DN)	Stroke (mm)	Dimensions (mm)						Weight (kg)
			L	H	d	D	K	C	
7219254010	65	30	290	137	8x18	185	145	22	16.7
7219258010	80	30	310	152	8x18	200	160	24	22.4
7219262010	100	30	350	171	8x22	235	190	24	32.5
7219266000	125	50	400	228	8x26	270	220	26	67
7219270000	150	50	480	288	8x26	300	250	28	97