

V222

Two-way Pressure Balanced Plug Valve, Flanged, PN16

The V222 is a flanged plug valve, designed for control of large flows in heating and air conditioning installations. The plug is balanced for high close off pressures from a low actuating force. Stainless steel plug and seat provide a long life in demanding applications.

The V222 valve can be used with the following types of fluids:

- Hot water, or deaerated cooling water.
- Deaerated water with glycol-type antifreeze agent (max. 50%).



Specifications

Design	Two-way pressure balanced plug valve	
Pressure class	PN 16	
Connection	Flange according ISO 7005-2	
Flow Characteristics	EQ%	
Stroke		
DN65-100	30 mm	
DN125-150	50 mm	
Rangeability		
Kvs / Kv _{min} (EN 60534-1)	>50	
Leakage	<0.05% of Kvs	
Stem		
DN65-100	M8	
DN125-150*	M16	
(* fitted with Hex Bush for M22/M50 actuators)		
Medium Temperature		
Maximum	150 °C	
Minimum*	-10 °C	
Main Construction Materials		
Body	Nodular iron GG25	
Stem	Stainless steel SS 1.4021	
Plug	Stainless steel SS 1.4021	
Seat	Stainless steel SS 1.4021	
Packing Box	Spring-loaded PTFE-V-ring	

* With cooling medias at temperatures below 0°C a stem heater must be fitted, to protect from stem seizure due to freezing.

Ordering Table

Size DN	Kvs (m ³ /h)	Part Number	Actuator
65	63	7212254010	M800, M1500, MV15B, M3000 M700, MG900
80	85	7212258010	
100	130	7212262010	
125	250	7212266000	M22, M50
150	350	7212270000	

- The rangability is the ratio of Kvs and Kv_{min}.
- Kvs is the flow capacity of a fully open valve, measured in m³/h at a pressure drop of 100 kPa.
- Kv_{min} is the minimum controllable flow at a pressure drop of 100 kPa, within the flow range where the characteristic meets the requirements on characteristic slope according to EN 60534-1.

Accessories and Spare Parts

	DN 65-100	DN 125-150
Gland Service Kit	100108201	100108210
Stem Heater	8800112000	8800113000
Hex Bush: Valve to actuator stem coupling	-	8800135000

Valve and Actuator Sizing Tables

Size DN	Kvs (m ³ /h)	ΔP_m (kPa)	Max Close Pressure, ΔP_c (kPa)						
			M800	M1500/ MV15B	M3000	MG900 SR	M700 SR	M22**	M50**
65	63	800	1500	2500	2500	1500	1200	-	
80	85	400				1100	800		
100	130	150	1100	1600	1100	800			
125	250	100	-					1800	2500
150	350	100						1400	

ΔP_c = Maximum allowed pressure differential across a closed valve (a function of actuator performance)
 ΔP_m = Maximum allowed pressure drop across a fully 'open' valve (a function of hydronic valve performance)
 **M22 and M50 actuators will not fit to valves DN65-100

Installation

The valve should be mounted with flow direction in accordance with the valve marking. It is recommended to install the valve in the return pipe, in order to avoid exposing the actuator to high temperatures. The valve must not be installed with the actuator mounted below the valve.

To ensure that suspended solids will not become jammed between the valve plug and seat, a filter should be installed upstream of the valve, and the pipe system should be flushed before the valve is installed.

System Schematics

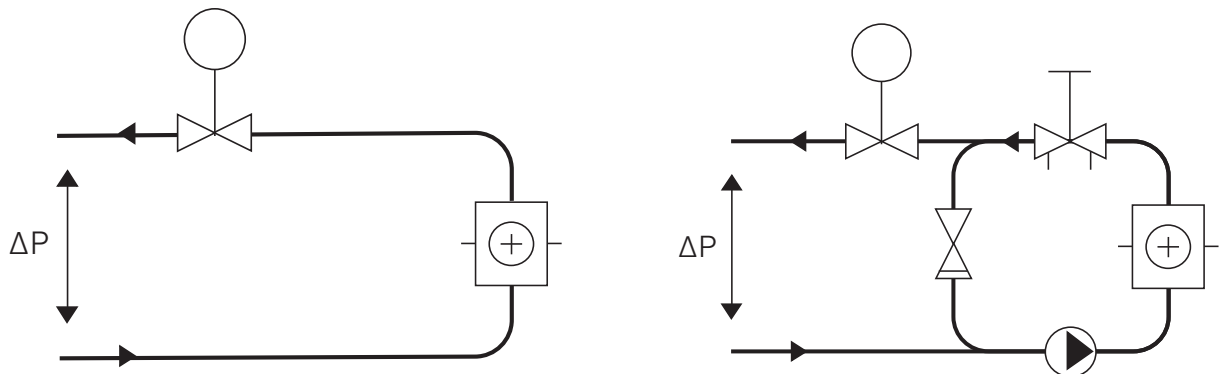

A. Typical installation without local circulation pump. To obtain good function the pressure drop across the valve should be no less than half of the available pressure drop (ΔP). This will give a valve authority of 50%.

B. Typical installation with local circulation pump. The Kvs value of the valve is to be selected so that the entire available pressure drop (ΔP) falls across the control valve.

Flow Capacity / Pressure Drop Charts, Fully Open Valve

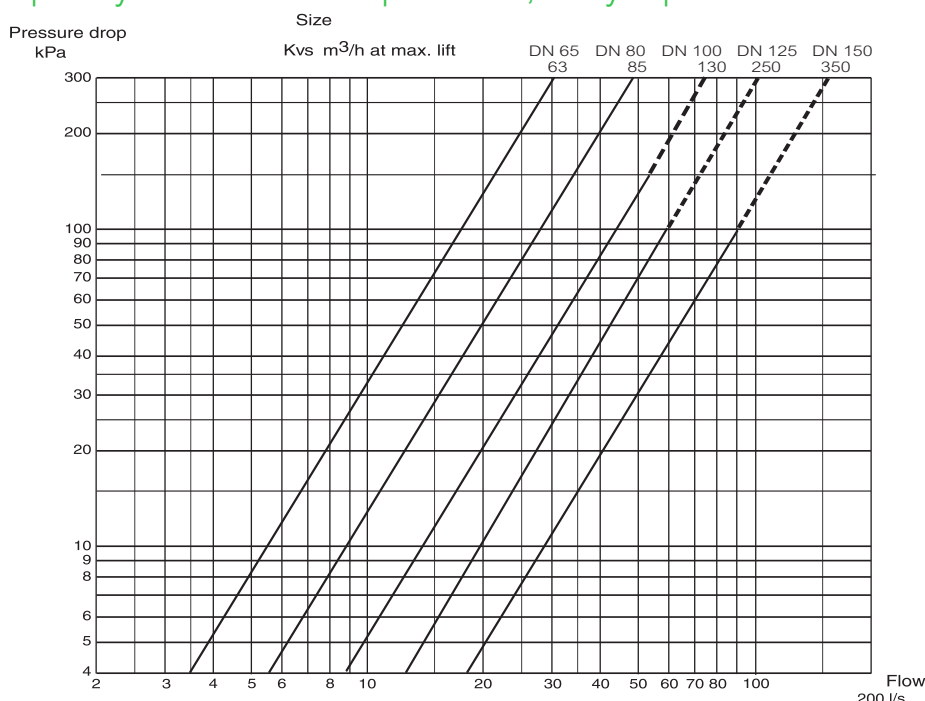

Cavitation

If the computed pressure drop exceeds the value read from the diagram, there is risk of cavitation. In general the flow velocity of the media should be under 2 m/s^{-1}

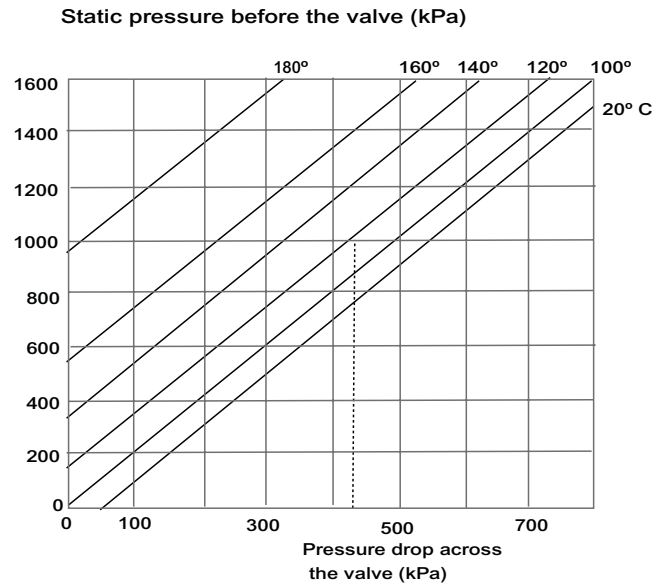

EQ % flow characteristic

The flow characteristic of the V222 is equal percentage (EQ%, also called logarithmic), giving an equal-percentage change in flow. This is necessary to give good linear heat transfer control in systems with large load variations.

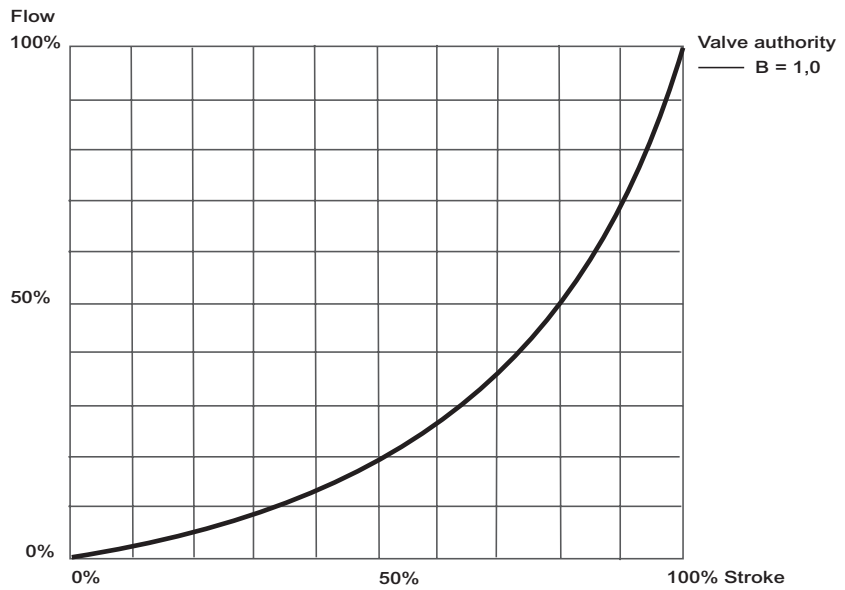

Dimensions and Weight

DN 65-100

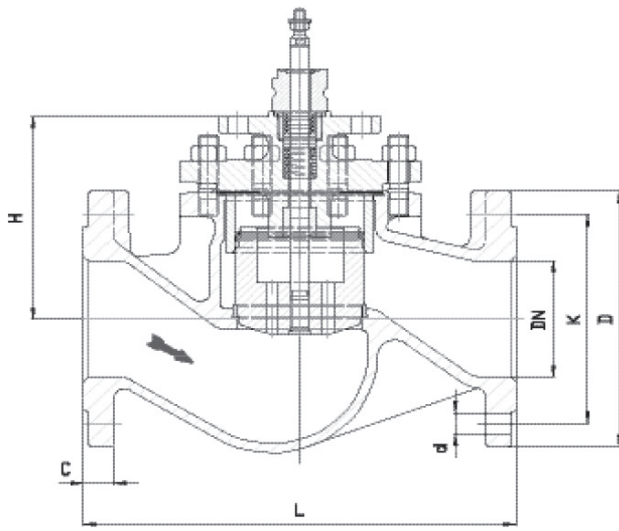

DN 125-150

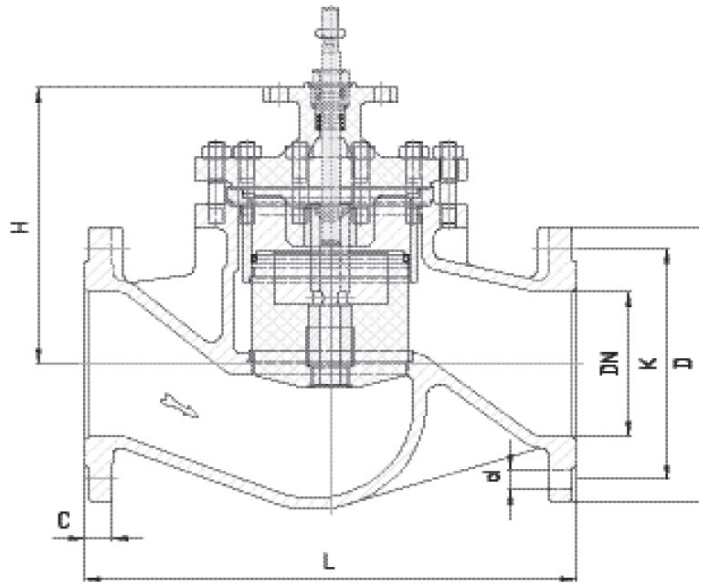

Part No.	Size	Stroke	Dimensions (mm)						Weight kg
			L	H	d	D	K	C	
7212254010	65	30	290	137	4x18	185	145	20	16.8
7212258010	80		310	152	8x18	200	160	22	22.9
7212262010	100		350	171	8x22	235	190	24	36.9
7212267000	125	50	400	228	8x26	270	220	26	63.0
7212270000	150		480	288		300	250	28	93.0